



# Standard Test Method for Half-Cell Potentials of Uncoated Reinforcing Steel in Concrete<sup>1</sup>

This standard is issued under the fixed designation C 876; the number immediately following the designation indicates the year of original adoption or, in the case of revision, the year of last revision. A number in parentheses indicates the year of last reapproval. A superscript epsilon ( $\epsilon$ ) indicates an editorial change since the last revision or reapproval.

## 1. Scope

1.1 This test method covers the estimation of the electrical half-cell potential of uncoated reinforcing steel in field and laboratory concrete, for the purpose of determining the corrosion activity of the reinforcing steel.

1.2 This test method is limited by electrical circuitry. A concrete surface that has dried to the extent that it is a dielectric and surfaces that are coated with a dielectric material will not provide an acceptable electrical circuit. The basic configuration of the electrical circuit is shown in Fig. 1.

1.3 The values stated in inch-pound units are to be regarded as the standard.

1.4 *This standard does not purport to address the safety-concerns, if any, associated with its use. It is the responsibility of the user of this standard to establish appropriate safety and health practices and determine the applicability of regulatory limitations prior to use.*

## 2. Referenced Documents

2.1 *ASTM Standards:*

G 3 Practice for Conventions Applicable to Electrochemical Measurements in Corrosion Testing<sup>2</sup>

## 3. Significance and Use

3.1 This test method is suitable for in-service evaluation and for use in research and development work.

3.2 This test method is applicable to members regardless of their size or the depth of concrete cover over the reinforcing steel.

3.3 This test method may be used at any time during the life of a concrete member.

3.4 The results obtained by the use of this test method shall not be considered as a means for estimating the structural properties of the steel or of the reinforced concrete member.

3.5 The potential measurements should be interpreted by engineers or technical specialists experienced in the fields of concrete materials and corrosion testing. It is often necessary to

use other data such as chloride contents, depth of carbonation, delamination survey findings, rate of corrosion results, and environmental exposure conditions, in addition to half-cell potential measurements, to formulate conclusions concerning corrosion activity of embedded steel and its probable effect on the service life of a structure.

## 4. Apparatus

4.1 The testing apparatus consists of the following:

### 4.1.1 Half Cell:

4.1.1.1 A copper-copper sulfate half cell (Note 1) is shown in Fig. 2. It consists of a rigid tube or container composed of a dielectric material that is nonreactive with copper or copper sulfate, a porous wooden or plastic plug that remains wet by capillary action, and a copper rod that is immersed within the tube in a saturated solution of copper sulfate. The solution shall be prepared with reagent grade copper sulfate crystals dissolved in distilled or deionized water. The solution may be considered saturated when an excess of crystals (undissolved) lies at the bottom of the solution.

4.1.1.2 The rigid tube or container shall have an inside diameter of not less than 1 in. (25 mm); the diameter of the porous plug shall not be less than 1/2 in. (13 mm); the diameter of the immersed copper rod shall not be less than 1/4 in. (6 mm), and the length shall not be less than 2 in. (50 mm).

4.1.1.3 Present criteria based upon the half-cell reaction of  $\text{Cu} \rightarrow \text{Cu}^{++} + 2e$  indicate that the potential of the saturated copper-copper sulfate half cell as referenced to the hydrogen electrode is  $-0.316$  V at  $72^\circ\text{F}$  ( $22.2^\circ\text{C}$ ). The cell has a temperature coefficient of about  $0.0005$  V more negative per  $^\circ\text{F}$  for the temperature range from  $32$  to  $120^\circ\text{F}$  ( $0$  to  $49^\circ\text{C}$ ).

NOTE 1—While this test method specifies only one type of half cell, that is, the copper-copper sulfate half cell, others having similar measurement range, accuracy, and precision characteristics may also be used. In addition to copper-copper sulfate cells, calomel cells have been used in laboratory studies. Potentials measured by other than copper-copper sulfate half cells should be converted to the copper-copper sulfate equivalent potential. The conversion technique can be found in Practice G 3 and it is also described in most physical chemistry or half-cell technology text books.

4.1.2 *Electrical Junction Device*—An electrical junction device shall be used to provide a low electrical resistance liquid bridge between the surface of the concrete and the half cell. It shall consist of a sponge or several sponges pre-wetted with a

<sup>1</sup> This test method is under the jurisdiction of ASTM Committee G01 on Corrosion of Metals and is the direct responsibility of Subcommittee G01.14 on Corrosion of Reinforcing Steel.

Current edition approved March 11, 1991. Published May 1991. Originally published as C 876 – 77. Last previous edition C 876 – 87.

<sup>2</sup> *Annual Book of ASTM Standards*, Vol 03.02.

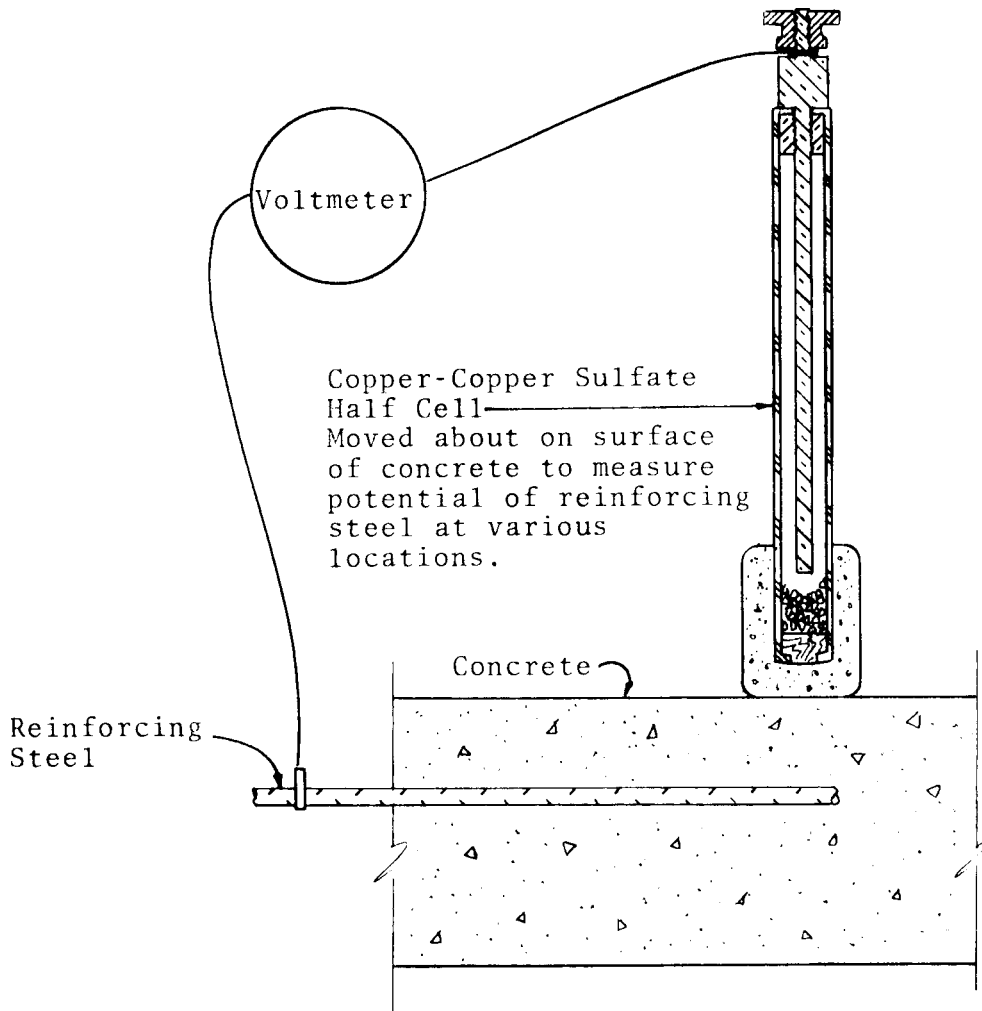

FIG. 1 Copper-Copper Sulfate Half Cell Circuitry

low electrical resistance contact solution. The sponge may be folded around and attached to the tip of the half cell so that it provides electrical continuity between the porous plug and the concrete member.

4.1.3 *Electrical Contact Solution*—In order to standardize the potential drop through the concrete portion of the circuit, an electrical contact solution shall be used to wet the electrical junction device. One such solution is composed of a mixture of 95 mL of wetting agent (commercially available wetting agent) or a liquid household detergent thoroughly mixed with 5 gal (19 L) of potable water. Under working temperatures of less than about 50°F (10°C), approximately 15 % by volume of either isopropyl or denatured alcohol must be added to prevent clouding of the electrical contact solution, since clouding may inhibit penetration of water into the concrete to be tested.

4.1.4 *Voltmeter*—The voltmeter shall have the capacity of being battery operated and have  $\pm 3$  % end-of-scale accuracy at the voltage ranges in use. The input impedance shall be no less than 10 M $\Omega$  when operated at a full scale of 100 mV. The divisions on the scale used shall be such that a potential difference of 0.02 V or less can be read without interpolation.

4.1.5 *Electrical Lead Wires*—The electrical lead wire shall be of such dimension that its electrical resistance for the length used will not disturb the electrical circuit by more than 0.0001

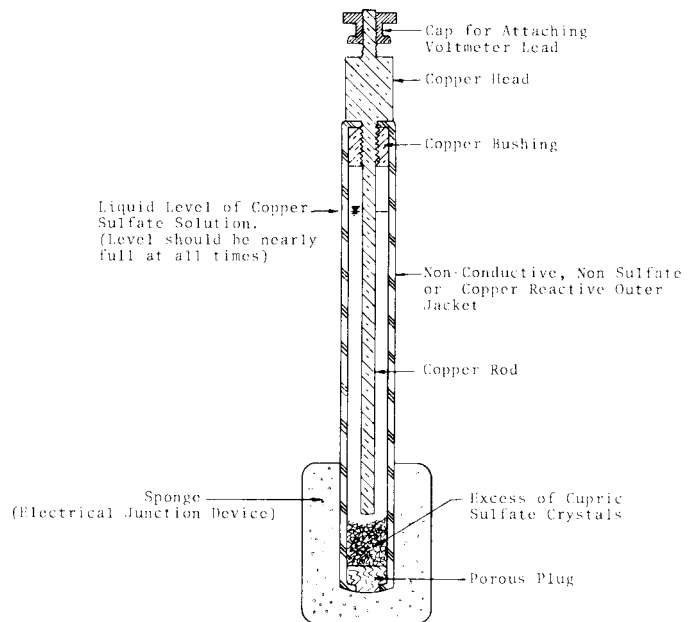

FIG. 2 Sectional View of a Copper-Copper Sulfate Half Cell

V. This has been accomplished by using no more than a total of

500 linear ft (150 m) of at least AWG No. 24 wire. The wire shall be suitably coated with direct burial type of insulation.

## 5. Calibration and Standardization

5.1 *Care of the Half Cell*—The porous plug shall be covered when not in use for long periods to ensure that it does not become dried to the point that it becomes a dielectric (upon drying, pores may become occluded with crystalline copper sulfate). If cells do not produce the reproducibility or agreement between cells described in Section 11, cleaning the copper rod in the half cell may rectify the problem. The rod may be cleaned by wiping it with a dilute solution of hydrochloric acid. The copper sulfate solution shall be renewed either monthly or before each use, whichever is the longer period. At no time shall steel wool or any other contaminant be used to clean the copper rod or half-cell tube.

## 6. Procedure

6.1 *Spacing Between Measurements*—While there is no pre-defined minimum spacing between measurements on the surface of the concrete member, it is of little value to take two measurements from virtually the same point. Conversely, measurements taken with very wide spacing may neither detect corrosion activity that is present nor result in the appropriate accumulation of data for evaluation. The spacing shall therefore be consistent with the member being investigated and the intended end use of the measurements (Note 2).

NOTE 2—A spacing of 4 ft (1.2 m) has been found satisfactory for evaluation of bridge decks. Generally, larger spacings increase the probability that localized corrosion areas will not be detected. Measurements may be taken in either a grid or a random pattern. Spacing between measurements should generally be reduced where adjacent readings exhibit algebraic reading differences exceeding 150 mV (areas of high corrosion activity). Minimum spacing generally should provide at least a 100-mV difference between readings.

### 6.2 *Electrical Connection to the Steel:*

6.2.1 Make a direct electrical connection to the reinforcing steel by means of a compression-type ground clamp, or by brazing or welding a protruding rod. To ensure a low electrical resistance connection, scrape the bar or brush the wire before connecting to the reinforcing steel. In certain cases, this technique may require removal of some concrete to expose the reinforcing steel. Electrically connect the reinforcing steel to the positive terminal of the voltmeter.

6.2.2 Attachment must be made directly to the reinforcing steel except in cases where it can be documented that an exposed steel member is directly attached to the reinforcing steel. Certain members, such as expansion dams, date plates, lift works, and parapet rails may not be attached directly to the reinforcing steel and, therefore, may yield invalid readings. Electrical continuity of steel components with the reinforcing steel can be established by measuring the resistance between widely separated steel components on the deck. Where duplicate test measurements are continued over a long period of time, identical connection points should be used each time for a given measurement.

6.3 *Electrical Connection to the Half Cell*—Electrically connect one end of the lead wire to the half cell and the other

end of this same lead wire to the negative (ground) terminal of the voltmeter.

### 6.4 *Pre-Wetting of the Concrete Surface:*

6.4.1 Under certain conditions, the concrete surface or an overlaying material, or both, must be pre-wetted by either of the two methods described in 6.4.3 or 6.4.4 with the solution described in 4.1.3 to decrease the electrical resistance of the circuit.

6.4.2 A test to determine the need for pre-wetting may be made as follows:

6.4.2.1 Place the half cell on the concrete surface and do not move.

6.4.2.2 Observe the voltmeter for one of the following conditions:

(a) The measured value of the half-cell potential does not change or fluctuate with time.

(b) The measured value of the half-cell potential changes or fluctuates with time.

6.4.2.3 If condition (a) is observed, pre-wetting the concrete surface is not necessary. However, if condition (b) is observed, pre-wetting is required for an amount of time such that the voltage reading is stable ( $\pm 0.02$  V) when observed for at least 5 min. If pre-wetting cannot obtain condition (a), either the electrical resistance of the circuit is too great to obtain valid half-cell potential measurements of the steel, or stray current from a nearby direct current traction system or other fluctuating direct-current, such as arc welding, is affecting the readings. In either case, the half-cell method should not be used.

6.4.3 *Method A for Pre-Wetting Concrete Surfaces*—Use Method A for those conditions where a minimal amount of pre-wetting is required to obtain condition (a) as described in 6.4.2.2. Accomplish this by spraying or otherwise wetting either the entire concrete surface or only the points of measurement as described in 6.1 with the solution described in 4.1.3. No free surface water should remain between grid points when potential measurements are initiated.

6.4.4 *Method B for Pre-Wetting Concrete Surfaces*—In this method, saturate sponges with the solution described in 4.1.3 and place on the concrete surface at locations described in 6.1. Leave the sponges in place for the period of time necessary to obtain condition (a) described in 6.4.2.2. Do not remove the sponges from the concrete surface until after the half-cell potential reading is made. In making the half-cell potential measurements, place the electrical junction device described in 4.1.2 firmly on top of the pre-wetting sponges for the duration of the measurement.

### 6.5 *Underwater, Horizontal, and Vertical Measurements:*

6.5.1 Potential measurements detect corrosion activity, but not necessarily the location of corrosion activity. The precise location of corrosion activity requires knowledge of the electrical resistance of the material between the half cell and the corroding steel. While underwater measurements are possible, results regarding the location of corrosion must be interpreted very carefully. Often it is not possible to precisely locate points of underwater corrosion activity in salt water environments because potential readings along the member appear uniform. However, the magnitude of readings does serve to indicate whether or not active corrosion is occurring. Take care during

all underwater measurements that the half cell does not become contaminated and that no part other than the porous tip of the copper-copper sulfate electrode half cell comes in contact with water.

6.5.2 Perform horizontal and vertically upward measurements exactly as vertically downward measurements. However, additionally ensure that the copper-copper sulfate solution in the half cell makes simultaneous electrical contact with the porous plug and the copper rod at all times.

**7. Recording Half-Cell Potential Values**

7.1 Record the electrical half-cell potentials to the nearest 0.01 V. Report all half-cell potential values in volts and correct for temperature if the half-cell temperature is outside the range of 72 ± 10°F (22.2 ± 5.5°C). The temperature coefficient for the correction is given in 4.1.1.3.

**8. Data Presentation**

8.1 Test measurements may be presented by one or both of two methods. The first, an equipotential contour map, provides a graphical delineation of areas in the member where corrosion activity may be occurring. The second method, the cumulative frequency diagram, provides an indication of the magnitude of affected area of the concrete member.

8.1.1 *Equipotential Contour Map*—On a suitably scaled plan view of the concrete member, plot the locations of the half-cell potential values of the steel in concrete and draw contours of equal potential through points of equal or interpolated equal values. The maximum contour interval shall be 0.10 V. An example is shown in Fig. 3.

8.1.2 *Cumulative Frequency Distribution*— To determine the distribution of the measured half-cell potentials for the concrete member, make a plot of the data on normal probability paper in the following manner:

8.1.2.1 Arrange and consecutively number all half-cell potentials by ranking from least negative potential to greatest negative potential.

8.1.2.2 Determine the plotting position of each numbered half-cell potential in accordance with the following equation:

$$f_x = \frac{r}{\sum n + 1} \times 100 \tag{1}$$

where:

- $f_x$  = plotting position of total observations for the observed value, %,
- $r$  = rank of individual half-cell potential, and
- $\sum n$  = total number of observations.

8.1.2.3 Label the ordinate of the probability paper “Half-Cell Potential (Volts, CSE),” where CSE is the designation for copper-copper sulfate electrode. Label the abscissa of the probability paper “Cumulative Frequency (%).” Draw two horizontal parallel lines intersecting the -0.20 and -0.35 V values on the ordinate, respectively, across the chart.

8.1.2.4 After plotting the half-cell potentials, draw a line of best fit through the value (Note 3). An example of a completed plot is shown in Fig. 4.

NOTE 3—It is not unusual to observe a break in the straight line. In these cases, the line of best fit shall be two straight lines that intersect at an angle.

**9. Interpretation of Results (See Refs. 1-8<sup>3</sup> and Appendix)**

9.1 Half-cell potentials are normally interpreted using a Numeric Magnitude Technique, or a Potential Difference Technique, or a combination of the two. Information on these techniques is presented in Appendix X1.

9.2 The numeric magnitude of the potential usually provides an indication of the presence or absence of corrosion of steel embedded in uncarbonated portland cement mortar or concrete, and near the half-cell tip, provided that the steel does not have a metallic coating, for example, is not galvanized. The numeric magnitude does not indicate the corrosion rate of the steel except under certain specific conditions.

9.3 The interpretations of half-cell potentials under conditions where the concrete is saturated with water, where it is carbonated at the depth of the reinforcing steel, where the steel is coated, and under many other conditions, requires an experienced corrosion engineer or specialist, and may require analyses for carbonation, metallic coatings, halides such as chloride or bromide, and other factors. Guidelines and test methods issued by ASTM Committee G-1 and the National Association of Corrosion Engineers can be very useful in investigations involving half-cell potential determinations.

9.4 Half-cell potentials may or may not be an indication of corrosion current. Half-cell potentials may in part or in whole reflect the chemistry of the electrode environment. For example, increasing concentrations of chloride can reduce the ferrous ion concentration at a steel anode, thus lowering (making more negative) the potential. Unless such chemistry, and the presence or absence of competing electrode reactions, is known, a half-cell potential should not be interpreted as indicative of corrosion rate, or even as indicative of a corrosion reaction.

**10. Report**

10.1 Report the following information:

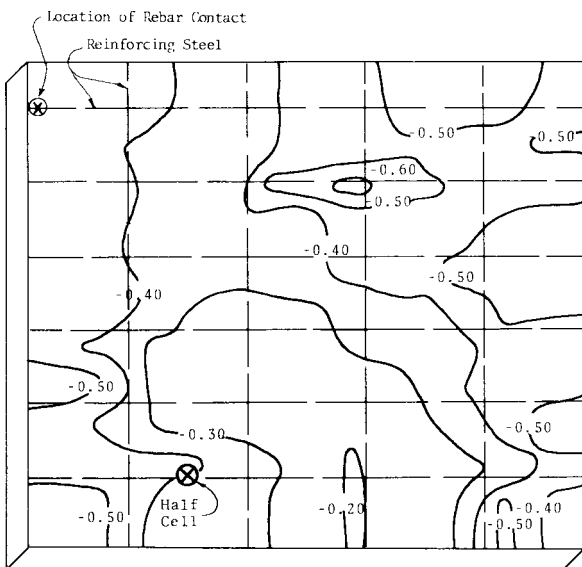

FIG. 3 Equipotential Contour Map

<sup>3</sup> References 1-8 are listed at the end of this test method.

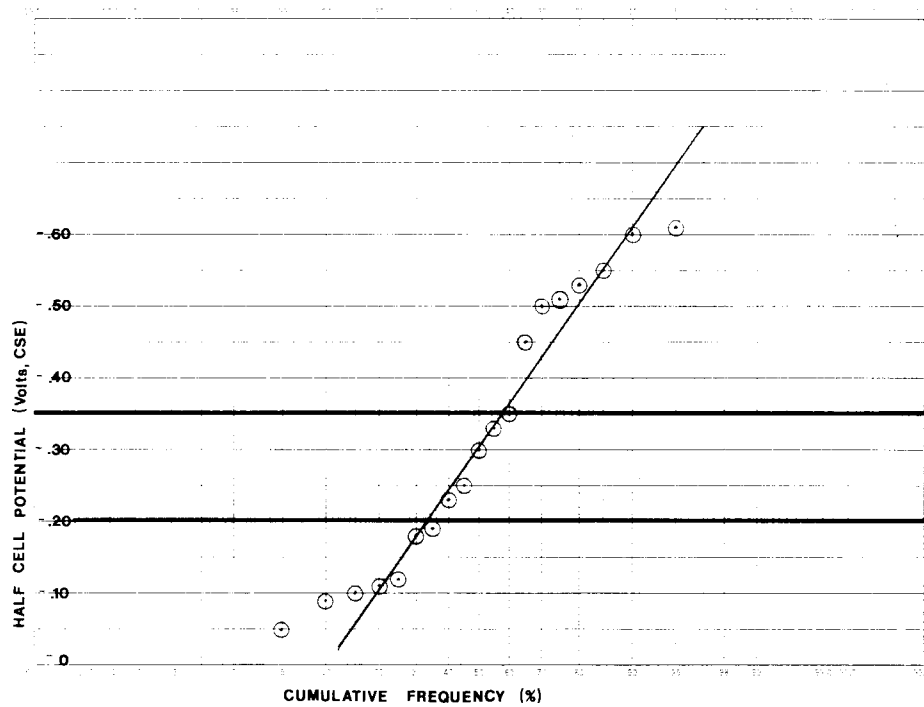

FIG. 4 Cumulative Frequency Diagram

- 10.1.1 Type of cell used if other than copper-copper sulfate,
- 10.1.2 The estimated average temperature of the half cell during the test,
- 10.1.3 The method for pre-wetting the concrete member and the method of attaching the voltmeter lead to the reinforcing steel,
- 10.1.4 An equipotential contour map, showing the location of reinforcing steel contact, or a plot of the cumulative frequency distribution of the half-cell potentials, or both,
- 10.1.5 The percentage of the total half-cell potentials that are more negative than  $-0.35$  V, and
- 10.1.6 The percentage of the total half-cell potentials that are less negative than  $-0.20$  V.

**11. Precision and Bias**

- 11.1 The difference between two half-cell readings taken at the same location with the same cell should not exceed 10 mV when the cell is disconnected and reconnected.
- 11.2 The difference between two half-cell readings taken at the same location with two different cells should not exceed 20 mV.

**12. Keywords**

12.1 concrete-corrosion activity; concrete-corrosion of reinforcing steel; corrosion; corrosion activity; electrical half-cell potentials; half-cell potentials

**APPENDIX**

(Nonmandatory Information)

**X1. NOTES ON THE HALF-CELL POTENTIAL TEST**

- X1.1 *Numeric Magnitude Technique*—Laboratory testing (partial immersion in chloride solutions) and outdoor exposure (including chloride exposure) of various reinforced concretes above-ground in an area in which the precipitation rate exceeded the evaporation rate, indicate the following regarding the significance of the numerical value of the potentials measured. Voltages listed are referenced to the copper-copper sulfate half cell.
  - X1.1.1 If potentials over an area are more positive than  $-0.20$  V CSE, there is a greater than 90 % probability that

- no reinforcing steel corrosion is occurring in that area at the time of measurement.
  - X1.1.2 If potentials over an area are in the range of  $-0.20$  to  $-0.35$  V CSE, corrosion activity of the reinforcing steel in that area is uncertain.
    - X1.1.3 If potentials over an area are more negative than  $-0.35$  V CSE, there is a greater than 90 % probability that reinforcing steel corrosion is occurring in that area at the time of measurement.
      - X1.1.4 These criteria should not normally be utilized under

the following conditions unless either experience or destructive examination of some areas, or both, suggest their applicability:

X1.1.4.1 To evaluate reinforcing steel in concrete that has carbonated to the level of the embedded steel,

X1.1.4.2 To evaluate indoor concrete that has not been subjected to frequent wetting unless it has been protected from drying after casting,

X1.1.4.3 To compare corrosion activity in outdoor reinforced concretes of highly variable moisture or oxygen content, or both, at the embedded steel, and

X1.1.4.4 To formulate conclusions concerning changes in corrosion activity with time on a rehabilitated structure in

which the rehabilitation caused the moisture or oxygen content, or both, at the embedded steel to change with time (example: installation of a low permeability overlay or waterproof membrane on a chloride-contaminated bridge or parking deck).

X1.2 *Potential Difference Technique*—Where large areas of electrically interconnected, embedded steel exist, for example, in bridge decks, reinforced columns, or beams, careful measurement of potentials in a closely spaced grid pattern and the subsequent plotting of equipotential contour maps may allow identification of high versus low corrosion rate areas (see References 1-8).

## REFERENCES

- (1) Spellman, D. L., and Stratfull, R. F., "Concrete Variables and Corrosion Testing," *Highway Research Record* 423, 1973.
- (2) Stratfull, R. F., "Half-Cell Potentials and the Corrosion of Steel in Concrete," *Highway Research Record* 433, 1973.
- (3) Clear, K. C., and Hay, R. E., "Time to Corrosion of Reinforcing Steel in Concrete Slabs," Vol. 1, *Federal Highway Administration Report FHWA-RD-73-32*, Washington, DC, April 1973.
- (4) Clear, K.C., "FCP Annual Progress Report-Year Ending September 30, 1981, Project 4K: Cost Effective Rigid Concrete Construction and Rehabilitation in Adverse Environments," Federal Highway Administration, Washington, DC, 1981.
- (5) Virmani, Y. P., Clear, K. C., and Pasko, T. J., Jr., "Time-to-Corrosion of Reinforcing Steel in Concrete Slabs," Vol. 5, *Federal Highway Administration Report FHWA/RD-83/012*, Washington, DC, September 1983.
- (6) ACI Committee 222, "Corrosion of Metals in Concrete," *ACI 222R-85*, American Concrete Institute, Detroit, MI, 1985.
- (7) "Durability of Concrete Bridge Decks," *NCHRP Synthesis of Highway Practice 57*, "Transportation Research Board, Washington, DC, May 1979.
- (8) Chamberlain, W. P., Irwin, R. J., and Amsler, D. E., "Waterproofing Membranes for Bridge Deck Rehabilitation," *Report No. FHWA-NY-77-59-1*, FHWA, 1977.

*The American Society for Testing and Materials takes no position respecting the validity of any patent rights asserted in connection with any item mentioned in this standard. Users of this standard are expressly advised that determination of the validity of any such patent rights, and the risk of infringement of such rights, are entirely their own responsibility.*

*This standard is subject to revision at any time by the responsible technical committee and must be reviewed every five years and if not revised, either reapproved or withdrawn. Your comments are invited either for revision of this standard or for additional standards and should be addressed to ASTM Headquarters. Your comments will receive careful consideration at a meeting of the responsible technical committee, which you may attend. If you feel that your comments have not received a fair hearing you should make your views known to the ASTM Committee on Standards, at the address shown below.*

*This standard is copyrighted by ASTM, 100 Barr Harbor Drive, PO Box C700, West Conshohocken, PA 19428-2959, United States. Individual reprints (single or multiple copies) of this standard may be obtained by contacting ASTM at the above address or at 610-832-9585 (phone), 610-832-9555 (fax), or service@astm.org (e-mail); or through the ASTM website (www.astm.org).*